

DMOS Dual Full Bridge PWM Motor Driver

Features and Benefits

- 36 V output rating
- 2.4 A, DC motor driver
- Synchronous rectification
- Internal undervoltage lockout (UVLO)
- Thermal shutdown circuitry
- Crossover-current protection
- Very thin profile QFN package

Package: 36 pin QFN
0.90 mm nominal height (suffix EV)

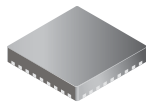

Approximate scale 1:1

Description

The A3995 is designed to drive two DC motors at currents up to 2.4 A. Capable of drive voltages up to 36 V, the A3995 includes two independent fixed off-time PWM current regulators that operate in either fast or slow decay mode, as determined by the MODE input. Internal synchronous rectification control circuitry is provided to improve power dissipation during PWM operation.

Protection features include: thermal shutdown with hysteresis, undervoltage lockout (UVLO) and crossover current protection. Special power-up sequencing is not required.

The A3995 is supplied in a 36 pin QFN package (suffix EV) with exposed power tab for enhanced thermal performance. It has a 6 mm × 6 mm footprint, with a nominal overall package height of 0.90 mm, and is lead (Pb) free, with 100% matte tin leadframe plating.

Typical Application Diagram

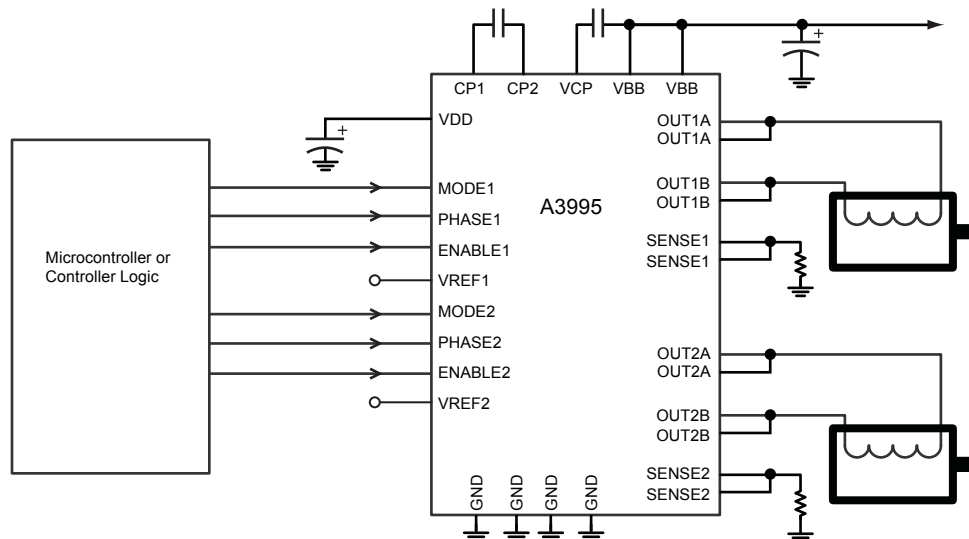

Selection Guide

Part Number	Packing
A3995SEVTR-T	1500 pieces per reel

Absolute Maximum Ratings

Characteristic	Symbol	Notes	Rating	Units
Load Supply Voltage	V_{BB}		-0.5 to 36	V
		Pulsed $t_w < 1 \mu s$	38	V
Logic Supply Voltage	V_{DD}		-0.4 to 7	V
Output Current*	I_{OUT}	Continuous	2.4	A
		Pulsed $t_w < 1 \mu s$	3.5	A
Logic Input Voltage Range	V_{IN}		-0.3 to 7	V
SENSEx Pin Voltage	V_{SENSEx}		0.5	V
		Pulsed $t_w < 1 \mu s$	2.5	V
VREFx Pin Voltage	V_{REFx}		2.5	V
Operating Temperature Range	T_A	Range S	-20 to 85	°C
Junction Temperature	$T_J(\max)$		150	°C
Storage Temperature Range	T_{stg}		-55 to 150	°C

* May be limited by duty cycle, ambient temperature, and heat sinking. Under any set of conditions, do not exceed the specified current rating or a Junction Temperature of 150°C.

Thermal Characteristics (may require derating at maximum conditions)

Characteristic	Symbol	Test Conditions	Min.	Units
Package Thermal Resistance	$R_{\theta JA}$	EV package, 4 layer PCB based on JEDEC standard	27	°C/W

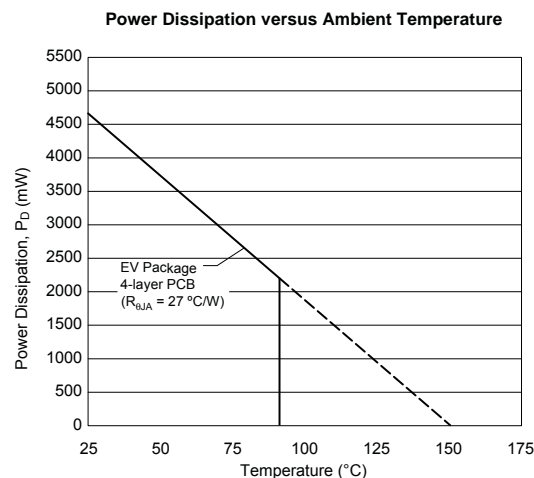

Functional Block Diagram

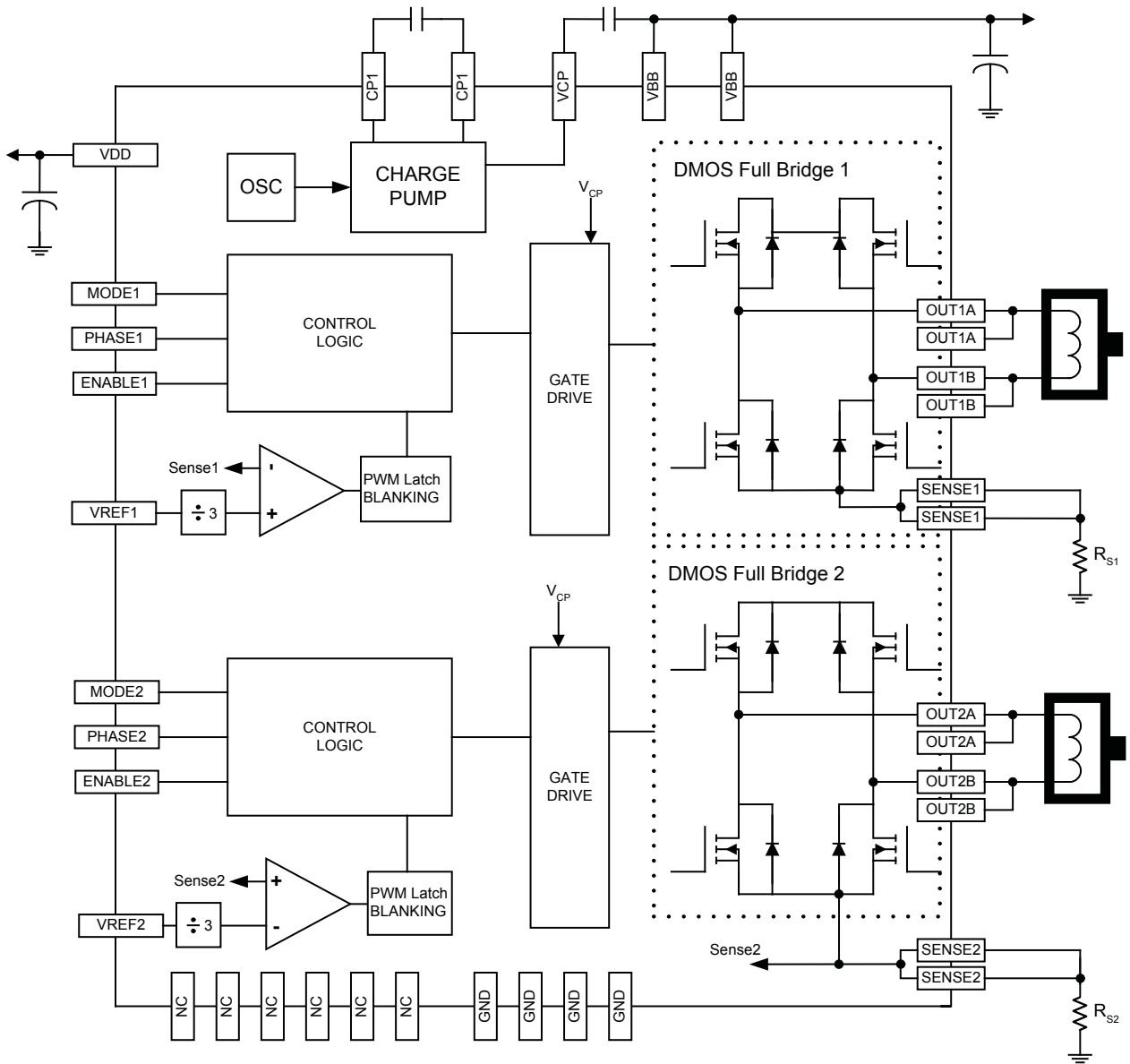

ELECTRICAL CHARACTERISTICS¹, valid at T_A = 25 °C, V_{BB} = 36 V, unless otherwise noted

Characteristics	Symbol	Test Conditions	Min.	Typ. ²	Max.	Units
Load Supply Voltage Range	V _{BB}	Operating	8.0	–	36	V
Logic Supply Voltage Range	V _{DD}	Operating	3.0	–	5.5	V
VDD Supply Current	I _{DD}		–	7	10	mA
Output On Resistance	R _{DS(on)}	Source driver, I _{OUT} = –1.2 A, T _J = 25°C	–	350	450	mΩ
		Sink driver, I _{OUT} = 1.2 A, T _J = 25°C	–	350	450	mΩ
V _f , Outputs		I _{OUT} = 1.2 A	–	–	1.3	V
Output Leakage	I _{DSS}	Outputs, V _{OUT} = 0 to V _{BB}	–20	–	20	μA
VBB Supply Current	I _{BB}	I _{OUT} = 0 mA, outputs on, PWM = 50 kHz, DC = 50%	–	–	8	mA
Control Logic						
Logic Input Voltage	V _{IN(1)}		0.7×V _{DD}	–	–	V
	V _{IN(0)}		–	–	0.3×V _{DD}	V
Logic Input Current	I _{IN}	V _{IN} = 0 to 5 V	–20	<1.0	20	μA
Input Hysteresis	V _{hys}		150	300	500	mV
Propagation Delay Times	t _{pd}	PWM change to source on	350	550	1000	ns
		PWM change to source off	35	–	300	ns
		PWM change to sink on	350	550	1000	ns
		PWM change to sink off	35	–	250	ns
Crossover Delay	t _{COD}		300	425	1000	ns
Blank Time	t _{BLANK}		2.5	3.2	4	μs
VREFx Pin Input Voltage Range	V _{REFx}	Operating	0.0	–	1.5	V
VREFx Pin Reference Input Current	I _{REF}	V _{REF} = 1.5	–	–	±1	μA
Protection Circuits						
VBB UVLO Threshold	V _{UV(VBB)}	V _{BB} rising	7.3	7.6	7.9	V
VBB Hysteresis	V _{UV(VBB)hys}		400	500	600	mV
VDD UVLO Threshold	V _{UV(VDD)}	V _{DD} rising	2.65	2.8	2.95	V
VDD Hysteresis	V _{UV(VDD)hys}		75	105	125	mV
Thermal Shutdown Temperature	T _{JTSD}		155	165	175	°C
Thermal Shutdown Hysteresis	T _{JTSDhys}		–	15	–	°C

¹For input and output current specifications, negative current is defined as coming out of (sourcing) the specified device pin.

²Typical data are for initial design estimations only, and assume optimum manufacturing and application conditions. Performance may vary for individual units, within the specified maximum and minimum limits.

³V_{ERR} = [(V_{REF}/3) – V_{SENSE}] / (V_{REF}/3).

DC Control Logic

PHASE	ENABLE	MODE	OUTA	OUTB	Function
1	1	1	H	L	Forward (slow decay SR)
1	1	0	H	L	Forward (fast decay SR)
0	1	1	L	H	Reverse (slow decay SR)
0	1	0	L	H	Reverse (fast decay SR)
X	0	1	L	L	Brake (slow decay SR)
1	0	0	L	H	Fast decay SR*
0	0	0	H	L	Fast decay SR*

* To prevent reversal of current during fast decay SR – the outputs will go to the high impedance state as the current gets near zero.

Logic Timing Diagram, DC Driver

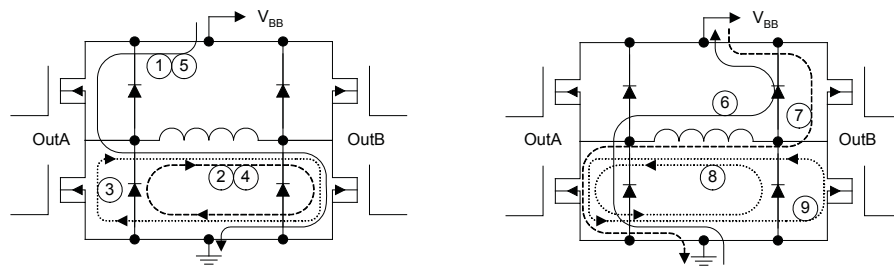
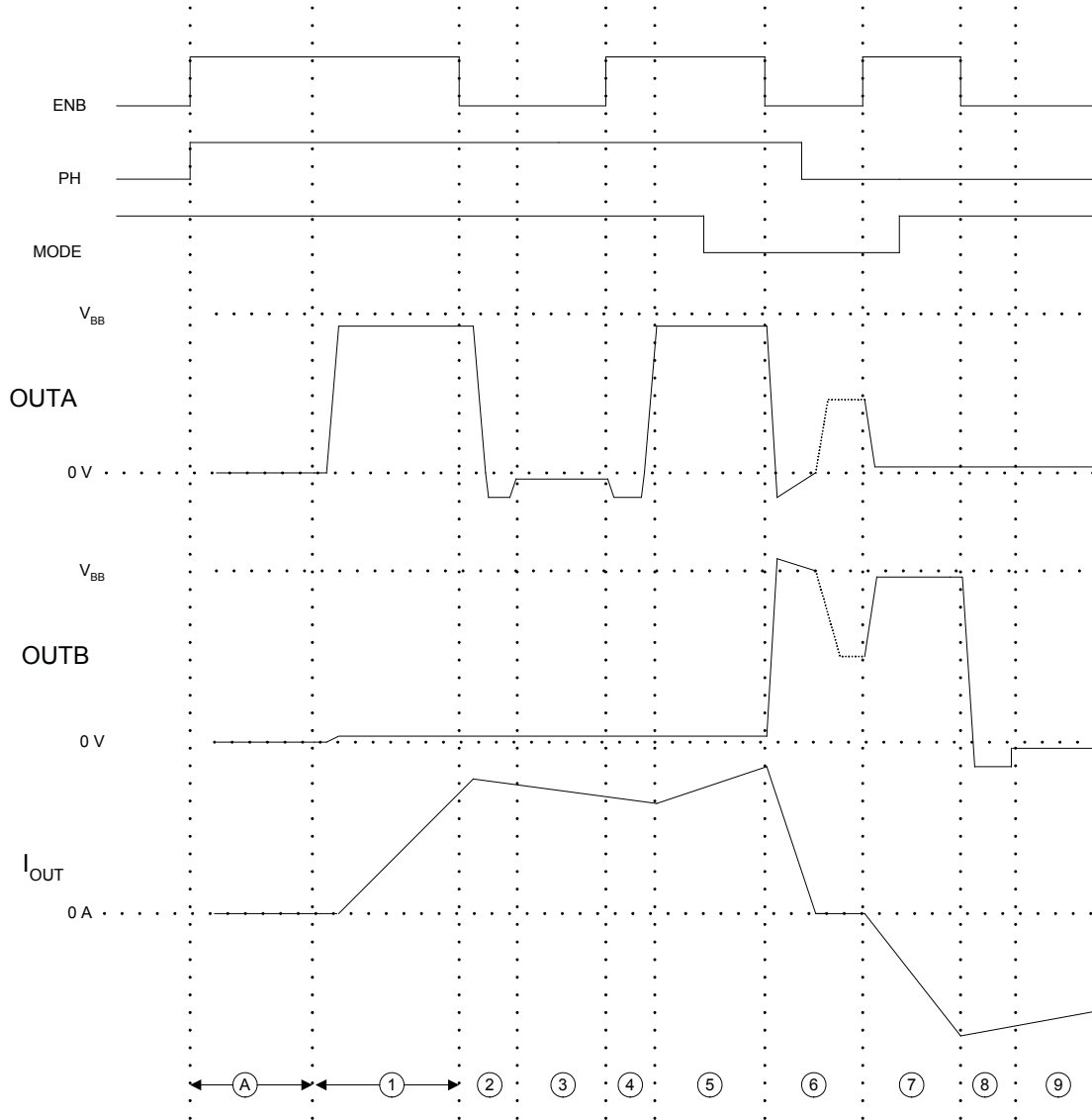

(A) Charge Pump and VREG Power-up Delay ($\approx 200 \mu\text{s}$)

Functional Description

Device Operation The A3995 is designed to operate two DC motors. The currents in each of the output full-bridges, all N-channel DMOS, are regulated with fixed off-time pulse width modulated (PWM) control circuitry. The peak current to each full bridge is set by the value of an external current sense resistor, R_{Sx} , and a reference voltage, V_{REFx} .

If the logic inputs are pulled up to VDD, it is good practice to use a high value pullup resistor in order to limit current to the logic inputs should an overvoltage event occur. Logic inputs include: PHASE_x, ENABLE_x, and MODE.

Internal PWM Current Control Each full-bridge is controlled by a fixed off-time PWM current control circuit that limits the load current to a desired value, I_{TRIP} . Initially, a diagonal pair of source and sink DMOS outputs are enabled and current flows through the motor winding and R_{Sx} . When the voltage across the current sense resistor equals the voltage on the VREF_x pin, the current sense comparator resets the PWM latch, which turns off the source driver.

The maximum value of current limiting is set by the selection of R_S and the voltage at the VREF input with a transconductance function approximated by:

$$I_{TripMax} = V_{REF} / (3 \times R_S)$$

Note: It is critical to ensure that the maximum rating of ± 500 mV on each SENSE_x pin is not exceeded.

Fixed Off-Time The internal PWM current control circuitry uses a one shot circuit to control the time the drivers remain off. The one shot off-time, t_{off} , is internally set to 30 μ s.

Blanking This function blanks the output of the current sense comparator when the outputs are switched by the internal current control circuitry. The comparator output is blanked to prevent false detections of overcurrent conditions, due to reverse recovery currents of the clamp diodes, or to switching transients related to the capacitance of the load. The driver blank time, t_{BLANK} , is approximately 3 μ s.

Phase Input (PHASE_x) The state of the PHASE_x input determines the direction of rotation of the motor.

Control Logic Dc motor commutation is accomplished by applying a PWM signal together with the PHASE or ENABLE inputs. Fast or slow current decay during the off-time is selected via the MODE pin. Synchronous Rectification is always active regardless of the state of the MODE pin.

Charge Pump (CP1 and CP2) The charge pump is used to generate a gate supply greater than the V_{BB} in order to drive the source-side DMOS gates. A 0.1 μ F ceramic capacitor should be connected between CP1 and CP2 for pumping purposes. A 0.1 μ F ceramic capacitor is required between VCP and VBB_x to act as a reservoir to operate the high-side DMOS devices.

Shutdown In the event of a fault (excessive junction temperature, or low voltage on VCP), the outputs of the device are disabled until the fault condition is removed. At power-up, the undervoltage lockout (UVLO) circuit disables the drivers.

Synchronous Rectification When a PWM-off cycle is triggered by an internal fixed off-time cycle, load current will recirculate. The A3995 synchronous rectification feature will turn on the appropriate MOSFETs during the current decay. This effectively shorts the body diode with the low $R_{DS(on)}$ driver. This significantly lowers power dissipation. When a zero current level is detected, synchronous rectification is turned off to prevent reversal of the load current.

MODE Control input MODE is used to toggle between fast decay mode and slow decay mode. A logic high puts the device in slow decay mode. Synchronous rectification is always enabled when ENABLE is low.

Braking The Braking function is implemented by driving the device in slow decay mode via the MODE pin and applying an ENABLE chop command. Because it is possible to drive current in both directions through the DMOS switches, this configuration effectively shorts the motor-generated BEMF as long as the ENABLE chop mode is asserted. The maximum current can be approximated by V_{BEMF}/R_L . Care should be taken to ensure that the maximum ratings of the device are not exceeded in worst case braking situations: high speed and high inertia loads.

Motor Configurations For applications that require either a stepper/DC motor driver or dual stepper motor driver, Allegro offers the A3989 and A3988. These devices are offered in the same QFN package as the A3995. The A3988 is capable of driving 2 bipolar stepper motors at output currents up to 1.2 A. The stepper control logic is industry standard parallel communication. Please refer to the Allegro website for further information and datasheets about those devices.

Layout The printed circuit board should use a heavy ground-plane. For optimum electrical and thermal performance, the A3995 must be soldered directly onto the board. On the underside of the A3995 package is an exposed pad, which provides a path for enhanced thermal dissipation. The thermal pad should be soldered directly to an exposed surface on the PCB. Thermal vias are used to transfer heat to other layers of the PCB.

Grounding In order to minimize the effects of ground bounce and offset issues, it is important to have a low impedance single-point ground, known as a *star ground*, located very close to the device. By making the connection between the exposed thermal pad and the groundplane directly under the A3995, that area becomes an ideal location for a star ground point.

A low impedance ground will prevent ground bounce during high current operation and ensure that the supply voltage remains stable at the input terminal. The recommended PCB layout shown in the diagram below, illustrates how to create a star ground under the device, to serve both as low impedance ground point and thermal path.

The two input capacitors should be placed in parallel, and as close to the device supply pins as possible. The ceramic capacitor should be closer to the pins than the bulk capacitor. This is necessary because the ceramic capacitor will be responsible for delivering the high frequency current components.

Sense Pins The sense resistors, RSx, should have a very low impedance path to ground, because they must carry a large current while supporting very accurate voltage measurements by the current sense comparators. Long ground traces will cause additional voltage drops, adversely affecting the ability of the comparators to accurately measure the current in the windings. As shown in the layout below, the SENSEx pins have very short traces to the RSx resistors and very thick, low impedance traces directly to the star ground underneath the device. If possible, there should be no other components on the sense circuits.

Note: When selecting a value for the sense resistors, be sure not to exceed the maximum voltage on the SENSEx pins of ± 500 mV.

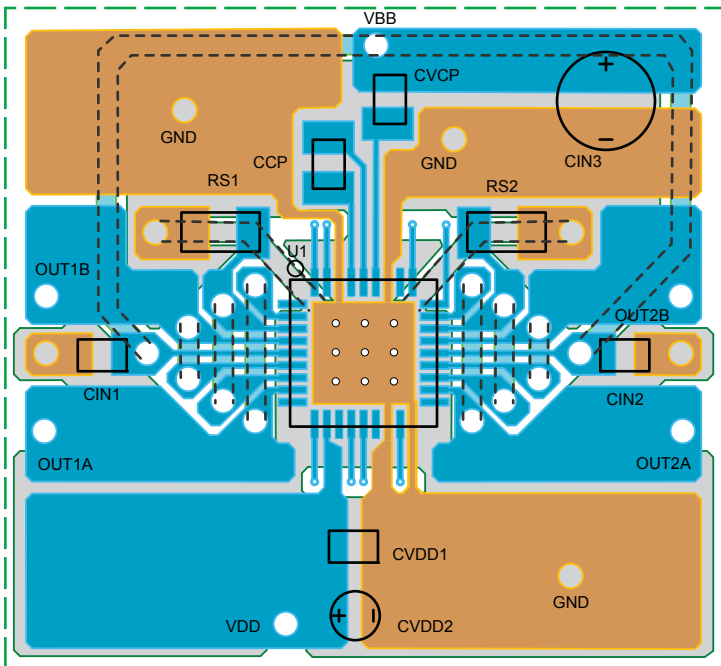

EV package layout shown.

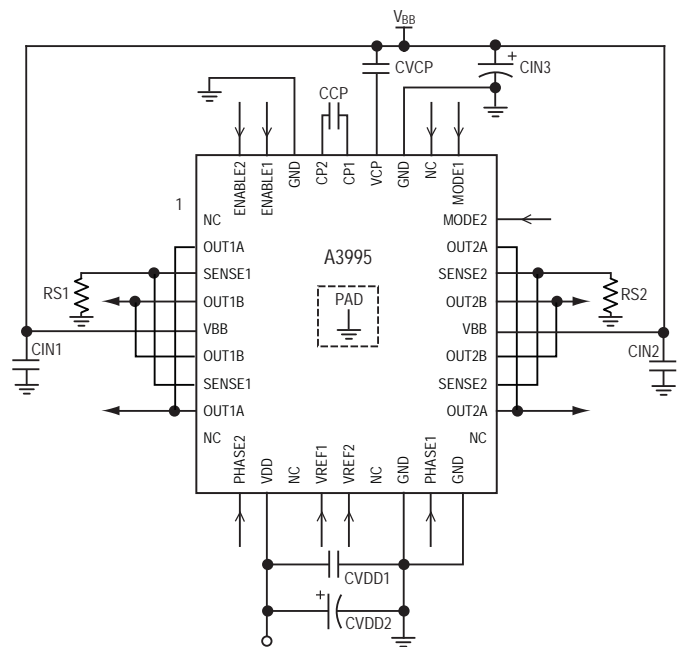
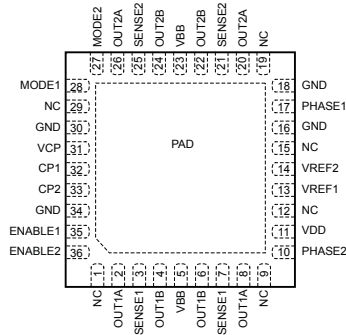

Figure 5. Printed circuit board layout with typical application circuit, shown at right. The copper area directly under the A3995 (U1) is soldered to the exposed thermal pad on the underside of the device. The thermal vias serve also as electrical vias, connecting it to the ground plane on the other side of the PCB, so the two copper areas together form the star ground.

Pin-out Diagram



Terminal List Table

Number	Name	Description
1	NC	No Connect
2	OUT1A	DMOS Full Bridge 1 Output A
3	SENSE1	Sense Resistor Terminal for Bridge 1
4	OUT1B	DMOS Full Bridge 1 Output B
5	VBB	Load Supply Voltage
6	OUT1B	DMOS Full Bridge 1 Output B
7	SENSE1	Sense Resistor Terminal for Bridge 1
8	OUT1A	DMOS Full Bridge 1 Output A
9	NC	No Connect
10	PHASE2	Control Input
11	VDD	Logic Supply Voltage
12	NC	No Connect
13	VREF1	Analog Input
14	VREF2	Analog Input
15	NC	No Connect
16	GND	Ground
17	PHASE1	Control Input
18	GND	Ground
19	NC	No Connect
20	OUT2A	DMOS Full Bridge 2 Output A
21	SENSE2	Sense Resistor Terminal for Bridge 2
22	OUT2B	DMOS Full Bridge 2 Output B
23	VBB	Load Supply Voltage
24	OUT2B	DMOS Full Bridge 2 Output B
25	SENSE2	Sense Resistor Terminal for Bridge 2
26	OUT2A	DMOS Full Bridge 2 Output A
27	MODE2	Control Input
28	MODE1	Control Input
29	NC	No Connect
30	GND	Ground
31	V _{CP}	Reservoir Capacitor Terminal
32	CP ₁	Charge Pump Capacitor Terminal
33	CP ₂	Charge Pump Capacitor Terminal
34	GND	Ground
35	ENABLE1	Control Input
36	ENABLE2	Control Input
-	PAD	Exposed pad for enhanced thermal performance. Should be soldered to the PCB

EV Package, 36 Pin QFN with Exposed Thermal Pad

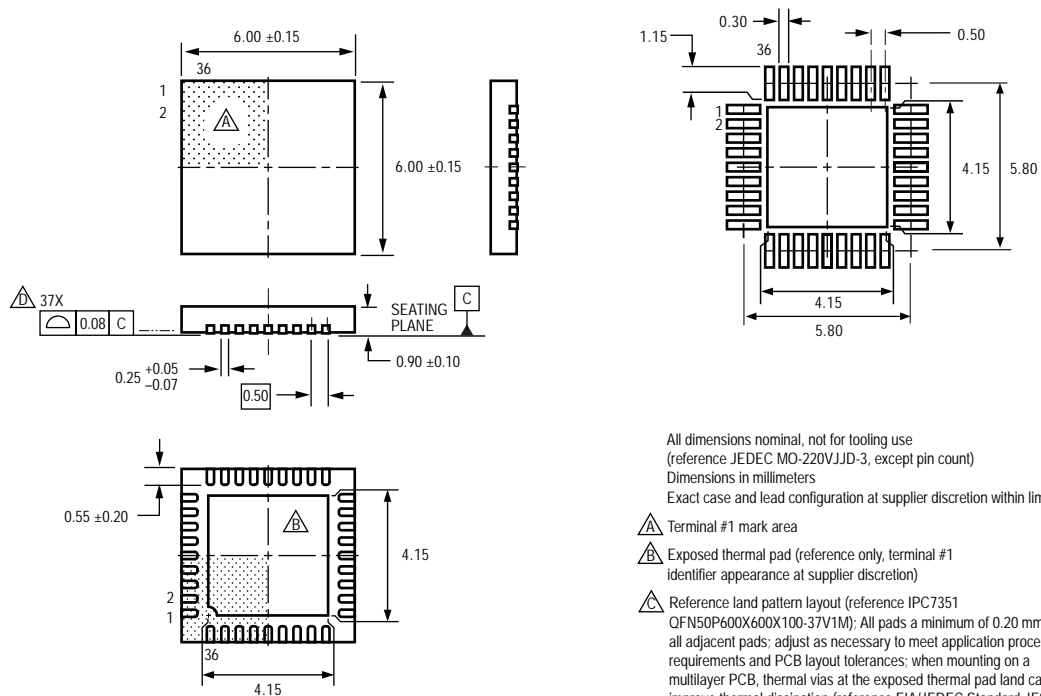

Copyright ©2006-2009, Allegro MicroSystems, Inc.

The products described here are manufactured under one or more U.S. patents or U.S. patents pending.

Allegro MicroSystems, Inc. reserves the right to make, from time to time, such departures from the detail specifications as may be required to permit improvements in the performance, reliability, or manufacturability of its products. Before placing an order, the user is cautioned to verify that the information being relied upon is current.

Allegro's products are not to be used in life support devices or systems, if a failure of an Allegro product can reasonably be expected to cause the failure of that life support device or system, or to affect the safety or effectiveness of that device or system.

The information included herein is believed to be accurate and reliable. However, Allegro MicroSystems, Inc. assumes no responsibility for its use; nor for any infringement of patents or other rights of third parties which may result from its use.

For the latest version of this document, visit our website:

www.allegromicro.com



Allegro MicroSystems, Inc.
115 Northeast Cutoff, Box 15036
Worcester, Massachusetts 01615-0036 (508) 853-5000
www.allegromicro.com