

SOT-23 Plastic-Encapsulate Transistors

BC807-16 TRANSISTOR (PNP)

BC807-25

BC807-40

FEATURES

- Ideally suited for automatic insertion
- epitaxial planar die construction
- complementary NPN type available(BC817)

MARKING: 807-16:5A; 807-25:5B; 807-40:5C

MAXIMUM RATINGS ($T_A=25^{\circ}\text{C}$ unless otherwise noted)

Symbol	Parameter	Value	Units
V_{CBO}	Collector-Base Voltage	-50	V
V_{CEO}	Collector-Emitter Voltage	-45	V
V_{EBO}	Emitter-Base Voltage	-5	V
I_C	Collector Current -Continuous	-0.5	A
P_C	Collector Power Dissipation	0.3	W
T_j	Junction Temperature	150	$^{\circ}\text{C}$
T_{stg}	Storage Temperature	-55-150	$^{\circ}\text{C}$

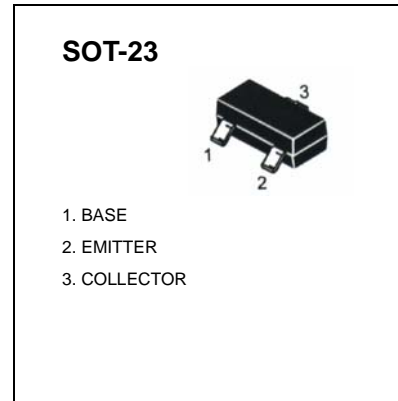

ELECTRICAL CHARACTERISTICS ($T_{amb}=25^{\circ}\text{C}$ unless otherwise specified)

Parameter	Symbol	Test conditions	MIN	MAX	UNIT
Collector-base breakdown voltage	V_{CBO}	$I_C = -10 \mu\text{A}, I_E = 0$	-50		V
Collector-emitter breakdown voltage	V_{CEO}	$I_C = -10\text{mA}, I_B = 0$	-45		V
Emitter-base breakdown voltage	V_{EBO}	$I_E = -1 \mu\text{A}, I_C = 0$	-5		V
Collector cut-off current	I_{CBO}	$V_{CB} = -45\text{V}, I_E = 0$		-0.1	μA
Collector cut-off current	I_{CEO}	$V_{CE} = -40\text{V}, I_B = 0$		-0.2	μA
Emitter cut-off current	I_{EBO}	$V_{EB} = -4\text{V}, I_C = 0$		-0.1	μA
DC current gain	$h_{FE(1)}$	$V_{CE} = -1\text{V}, I_C = -100\text{mA}$	807-16	100	250
			807-25	160	400
			807-40	250	600
Collector-emitter saturation voltage	$V_{CE(sat)}$	$I_C = -500\text{mA}, I_B = -50\text{mA}$		-0.7	V
Base-emitter saturation voltage	$V_{BE(sat)}$	$I_C = -500\text{mA}, I_B = -50\text{mA}$		-1.2	V
Transition frequency	f_T	$V_{CE} = -5\text{V}, I_C = -10\text{mA}$ $f = 100\text{MHz}$	100		MHz

Typical Characteristics

BC807-16/-25/-40

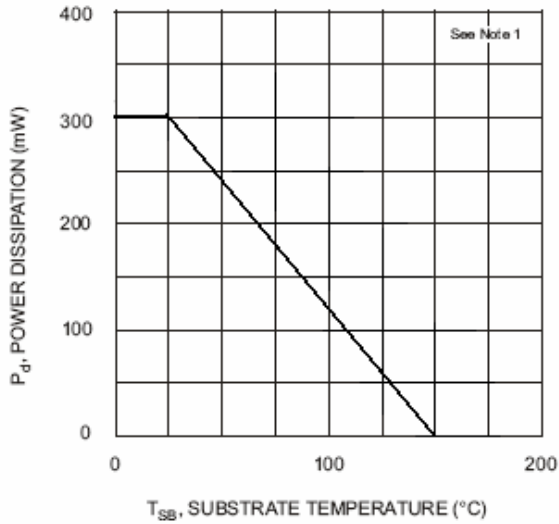

Fig. 1, Power Derating Curve

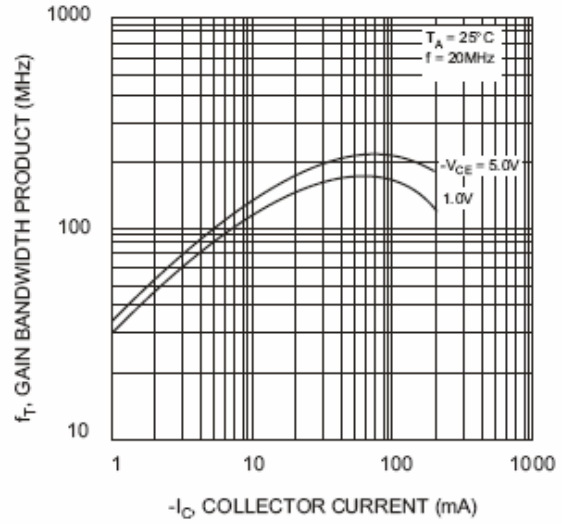

Fig. 2, Gain-Bandwidth Product vs Collector Current

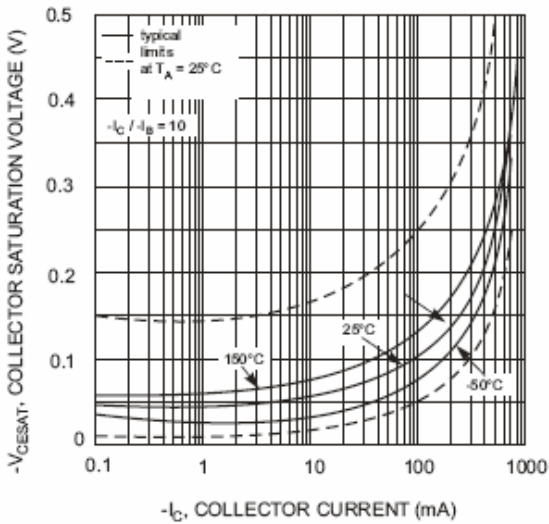

Fig. 3, Collector Sat Voltage vs Collector Current

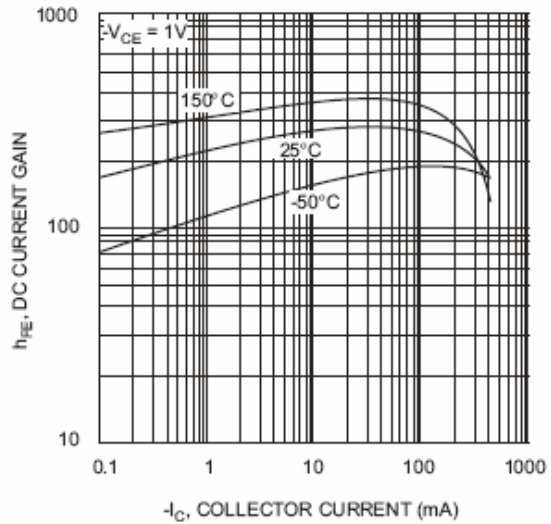

Fig. 4, DC Current Gain vs Collector Current

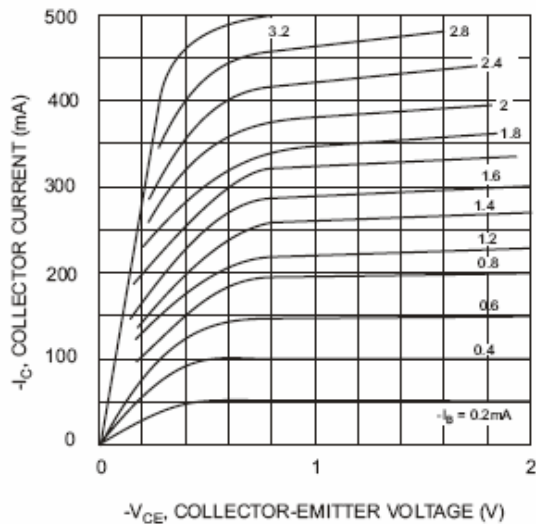

Fig. 5, Typical Emitter-Collector Characteristics

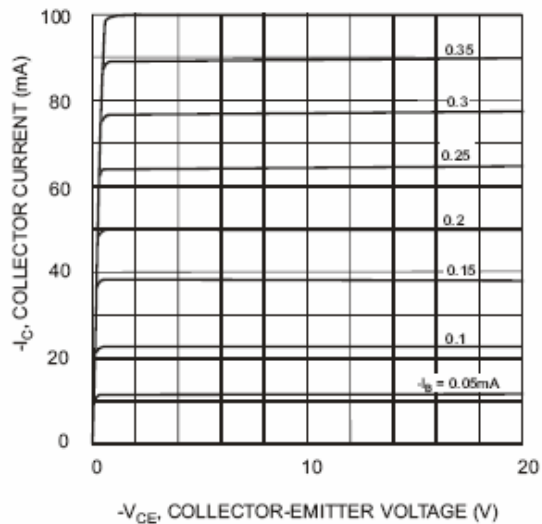

Fig. 6, Typical Emitter-Collector Characteristics