

**RFM68W - Low Cost Integrated Transmitter MODULE****V: 1.0****Features****GENERAL  
DESCRIP  
TION**

The RFM68W is an ultra-low-cost, fully integrated FSK or OOK transmitter suitable for operation between 310 and 450 MHz, 860 and 870 MHz, as well as 902 and 928 MHz. For applications where economy is paramount, the RFM68W may be used without the requirement for configuration via an MCU. However, in conjunction with a microcontroller the communication link parameters may be re-configured. Including, output power, modulation format and operating channel.

The RFM68W offers integrated radio performance with cost efficiency and is suited for operation in North America FCC part 15.231, FCC part 15.247 DTS and FHSS modes, 15.249, and Europe EN 300 220.

**APPLICATIONS**

- ◆ Garage Door Openers
- ◆ Low-Cost Consumer Electronic Applications
- ◆ Remote Keyless Entry (RKE)
- ◆ Remote Control / Security Systems

**KEY PRODUCT FEATURES**

- ◆ +10 dBm or 0 dBm Configurable output power
- ◆ Bit rates up to 100 kbps
- ◆ OOK and FSK modulation.
- ◆ 1.8 to 3.7 V supply range.
- ◆ Low BOM Fully Integrated Tx
- ◆ Fractional-N PLL with 1.5 kHz typical step
- ◆ Frequency agility for FHSS modulation
- ◆ FCC Part 15.247 DTS Mode compliant

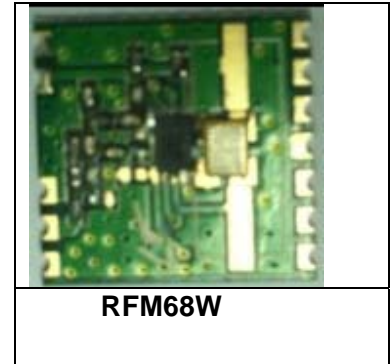

## Table of contents

Section	Page
1. Circuit Description.....	3
1.1. General Description .....	3
1.2. Block Diagram.....	3
1.3. Pin Description,.....	4
2. Electrical Characteristics .....	5
2.1. ESD Notice .....	5
2.2. Absolute Maximum Ratings .....	5
2.3. Operating Range.....	5
2.4. Electrical Specifications.....	6
3. Timing Characteristics .....	7
4. Application Modes of the RF68.....	8
4.1. Transmitter Modes .....	8
4.2. Mode Selection Flowchart.....	9
4.3. Application Mode: Power & Go .....	10
4.4. Application Mode: Advanced .....	10
4.4.1. Advanced Mode: Configuration.....	10
4.4.2. Frequency Hopping Spread Spectrum.....	10
4.5. Frequency Band Coverage .....	11
4.6. Power Consumption.....	11
5. RFM68W Configuration.....	12
5.1. TWI Access.....	12
5.2. APPLICATION Configuration Parameters .....	14
5.3. FREQUENCY Configuration Parameters .....	14
5.4. Test Parameters (internal) .....	15
5.5. Status Parameters .....	15
5.6. Recovery Command .....	16
6. Application Information .....	17
6.1. Crystal Specification .....	17
6.2. Reference Design .....	17
6.3. NRESET Pin .....	18
6.4. TX_READY Pin.....	18
6.5. Low Power Optimization .....	18
6.5.1. 2 Connections: CTRL, DATA .....	18
6.5.2. 3 Connections: CTRL, DATA, TX_READY .....	18
7. RFM68W Packaging .....	19
7.1. Package Outline Drawing .....	19
7.2. Land Pattern .....	19

This product datasheet contains a detailed description of the RFM68W performance and functionality.

## 1. Circuit Description

### 1.1. General Description

The RFM68W is a fully-integrated multi-band, single chip transmitter IC capable of FSK and OOK modulation of an input data stream.

It contains a frequency synthesizer which is a fractional-N sigma-delta PLL. For frequency modulation (FSK), the modulation is made inside the PLL bandwidth. For amplitude modulation (OOK), the modulation is performed by turning on and off the output PA.

The frequency reference used by the PLL is generated by a 22, 24 or 26 MHz crystal oscillator, depending on the frequency band of interest.

The Power Amplifier (PA), connected to the RFOUT pin, can deliver 0 dBm or +10 dBm in a 50 Ω load. Each of these two output powers need a specific matching network when efficiency needs to be optimized.

The circuit can be configured via a simplified TWI interface, constituted of pin CTRL and DATA. The pins of this interface are also used to transmit the modulating data to the chip.

Another key feature of the RFM68W is its low current consumption in Transmit and Sleep modes and its wide voltage operating range from 1.8 V to 3.7 V. This makes the RF68 suitable for low-cost battery chemistries or energy harvesting applications.

### 1.2. Block Diagram

The figure below shows the simplified block diagram of the RFM68W

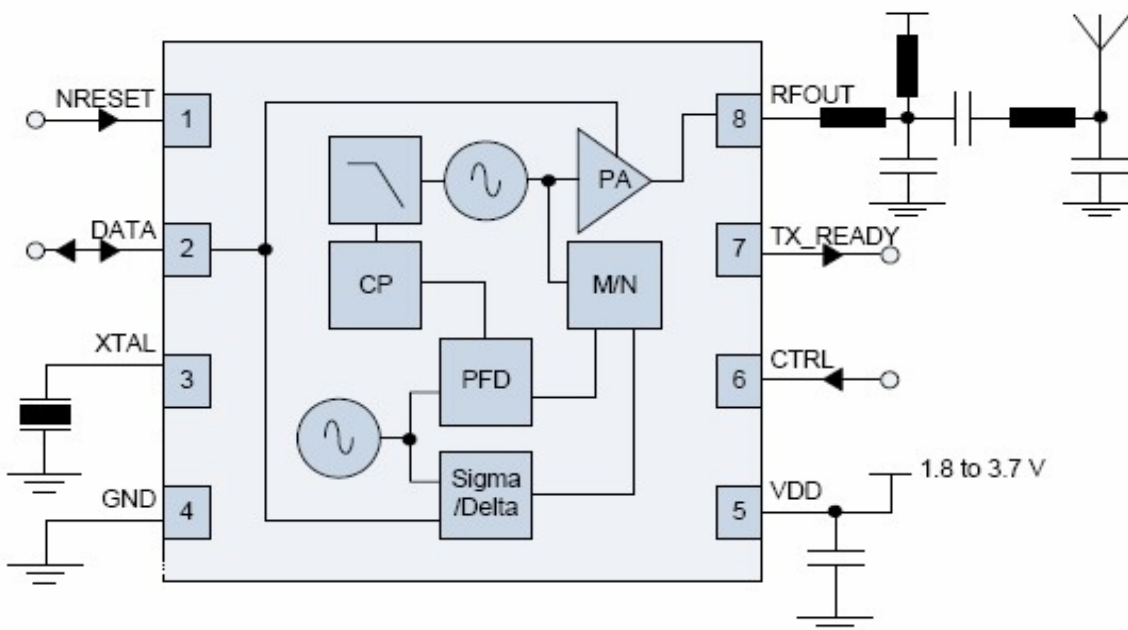

## 1.3. Pin Description

Table 1 Description of the RFM68W

### Pin Diagram (TOP)

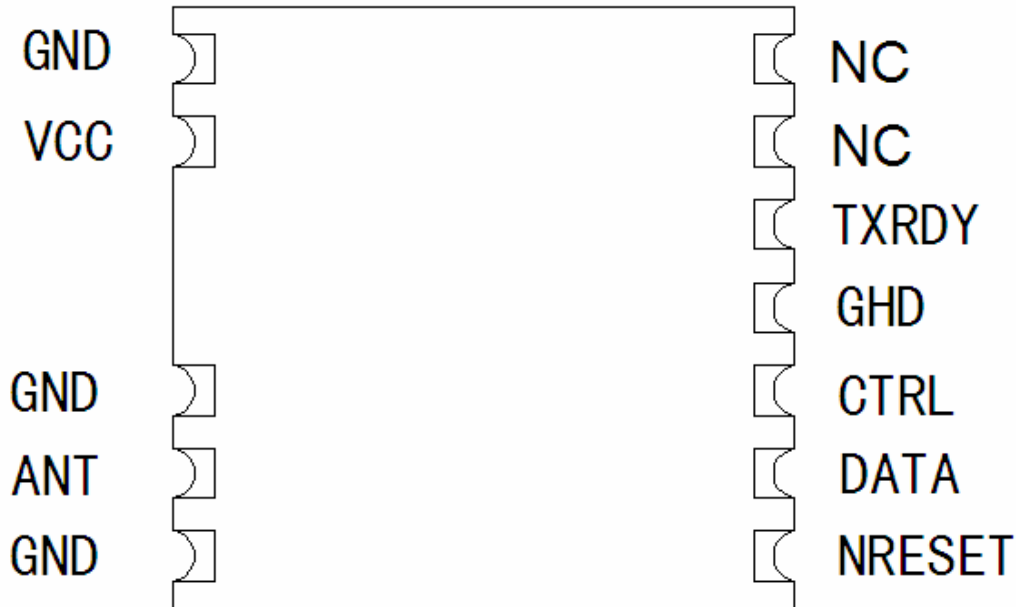

## Pin Description

Number	Name	Type	Description
1	GND	I	Exposed Pad, Ground
2	ANT	O	Transmitter RF Output
3	GND	I	Exposed Pad, Ground
4	VCC	I	Power Supply 1.8V to 3.7V
5	GND	I	Exposed Pad, Ground
6	NRESET	I	Reset (Optional, can be left floating)
7	DATA	I/O	Transmit or Configuration Data
8	CTRL	I	Config Selection Configuration Data Clock
9	GND	I	Exposed Pad, Ground
10	TX_READY	O	Transmitter Ready Flag (Optional, can be left floating)
11	NC	-	Connect to GND
12	NC	-	Connect to GND

## 2. Electrical Characteristics

### 2.1. ESD Notice

The RFM68W is an electrostatic discharge sensitive device. It satisfies Class 2 of the JEDEC standard JESD22-A114-B (human body model) on all pins.



### 2.2. Absolute Maximum Ratings

Stresses above the values listed below may cause permanent device failure. Exposure to absolute maximum ratings for extended periods may affect device reliability.

Table 2 Absolute Maximum Ratings

Symbol	Description	Min	Max	Unit
VDDmr	Supply Voltage	-0.5	3.9	V
Tmr	Temperature	-55	115	° C
Tjunc	Junction Temperature	-55	125	° C
Tstor	Storage Temperature	-55	150	° C

### 2.3. Operating Range

Operating ranges define the limits for functional operation and the parametric characteristics of the device as described in this section. Functionality outside these limits is not implied.

Table 3 Operating Range

Symbol	Description	Min	Max	Unit
VDDop	Supply voltage	1.8	3.7	V
Top	Operational temperature range	-40	85	° C
Clop	Load capacitance on digital ports	-	25	pF

## 2.4. Electrical Specifications

The table below gives the electrical specifications of the transmitter under the following conditions: Supply voltage = 3.3 V, temperature = 25 °C,  $f_{XOSC} = 26$  MHz,  $f_{RF} = 915$  MHz, 2-FSK modulation with  $F_{dev} = \pm 10$  kHz, bit rate = 10 kbit/s and output power = +10 dBm terminated in a matched 50 Ohm impedance, unless otherwise specified.

Table 4 Transmitter Specifications

Symbol	Description	Conditions	Min	Typ	Max	Unit
<b>Current Consumption</b>						
IDDSL	Supply current in Sleep mode		-	0.5	1	µA
IDDT_315	Supply current in Transmit mode at 315 MHz*	RFOP=+10dBm 50% OOK	-	11	-	mA
		RFOP=+10dBm FSK	-	15	-	mA
		RFOP=0dBm FSK	-	9	-	mA
IDDT_915	Supply current in Transmit mode at 915 MHz*	RFOP=+10dBm FSK	-	17.5	-	mA
		RFOP=0dBm FSK	-	10.5	-	mA
<b>RF and Baseband Specifications</b>						
FBAND	Accessible Frequency Bands  See details in Table 7.	Band 0, with FXOSC=22 MHz	310	-	450	MHz
		Band 0, with FXOSC=24 MHz	312	-	450	MHz
		Band 0, with FXOSC=26 MHz	338	-	450	MHz
		Band 1, with FXOSC=26 MHz	860 902	- -	870 928	MHz MHz
FDA	Frequency deviation, FSK		10	-	200	kHz
BRF	Bit rate, FSK	Permissible Range	0.5	-	100	kbps
BRO	Bit rate, OOK	Permissible Range	0.5	-	10	kbps
OOK_B	OOK Modulation Depth		-	45	-	dB
RFOP	RF output power in 50 Ohms in either frequency band	High Power Setting	7	10	-	dBm
		Low Power Setting*	-3	0	-	dBm
RFOPFL	RF output power flatness	From 315 to 390 MHz, 50 Ohms load	-	2	-	dB
DRFOPV	Variation in RF output power with supply voltage	2.5 V to 3.3 V	-	-	3	dB
		1.8 V to 3.7 V	-	-	7	dB
PHN	Transmitter phase noise	At offset: 100 kHz	-	-82	-76	dBc/Hz
		350 kHz	-	-92	-81	dBc/Hz
		550 kHz	-	-96	-91	dBc/Hz
		1.15 MHz	-	-103	-101	dBc/Hz
STEP_22	RF frequency step	FXOSC = 22 MHz, Band 0	-	1.34277	-	kHz
STEP_24	RF frequency step	FXOSC = 24 MHz, Band 0	-	1.46484	-	kHz
STEP_26	RF frequency step	FXOSC = 26 MHz, Band 0	-	1.58691	-	kHz
		FXOSC = 26 MHz, Band 1	-	3.17383	-	kHz

Symbol	Description	Conditions	Min	Typ	Max	Unit
FXOSC	Crystal Oscillator Frequency		-	22	-	MHz
			-	24	-	MHz
			-	26	-	MHz
DFXOSC	Frequency Variation of the XOSC	No crystal contribution	-	-	+/-25	ppm
<b>Timing Specifications</b>						
TS_TR	Time from Sleep to Tx mode	XTAL dependant, with spec'd XTAL	-	650	2000	us
TS_HOP0	Channel hop time in Band 0	315 to 390 MHz	-	250	500	us
TS_HOP1	Channel hop time in Band 1	Maximum hop of 26 MHz***	-	200	400	us
TOFFT	Timer from Tx data activity to Sleep	Programmable	-	2	-	ms
			-	20	-	ms
RAMP	PA Ramp up and down time		-	20	-	us
T_START	Time before CTRL pin mode selection.	Time from power on to sampling of CTRL **	-	200 us + TS_OSC	-	ms

\* With different matching networks

\*\* The oscillator startup time, TS\_OSC, depends on the electrical characteristics of the crystal

\*\*\* From the last CTRL falling edge of the Frequency change instruction to transmitter ready (PA ramp up finished)

### 3. Timing Characteristics

The following table gives the operating specifications for the TWI interface of the RFM68W.

Table 5 Serial Interface Timing Specifications

Symbol	Description	Conditions	Min	Typ	Max	Unit
f_CTRL	CTRL Clock Frequency		-	-	10	MHz
t <sub>ch</sub>	CTRL Clock High time		45	-	-	ns
t <sub>cl</sub>	CTRL Clock Low time		45	-	-	ns
t <sub>rise</sub>	CTRL Clock rise time		-	-	5	ns
t <sub>fall</sub>	CTRL Clock Fall time		-	-	5	ns
t <sub>setup</sub>	DATA Setup time	From Data transition to CTRL rising edge	45	-	-	ns
t <sub>hold</sub>	DATA hold time	From CTRL rising edge to DATA transition	45	-	-	ns
t <sub>0</sub> , t <sub>2</sub>	Time at "1" on DATA during Recovery command	See Figure 9 and Figure 10	-	-	5	us
t <sub>1</sub>	Time at "0" on DATA during Recovery command	See Figure 10	5	-	-	us

## 4. Application Modes of the RFM68W

Pins CTRL and DATA are used for both configuring the circuit and sending the data to be transmitted over the air. Two different modes are associated to these pins, “Power&Go” and “Advanced” modes.

### 4.1. Transmitter Modes

**Automatic Mode** operation is described in Figure 2. Here we see that a rising edge on the DATA pin activates the transmitter start-up process. DATA must be held high for the start-up time (TS\_TR) of the RFM68W. During this time the RFM68W undergoes an optimized, self-calibrating trajectory from Sleep mode to Transmit mode. Once this time has elapsed, the RFM68W is ready to transmit. Any logical signal subsequently applied to the DATA pin is then transmitted.

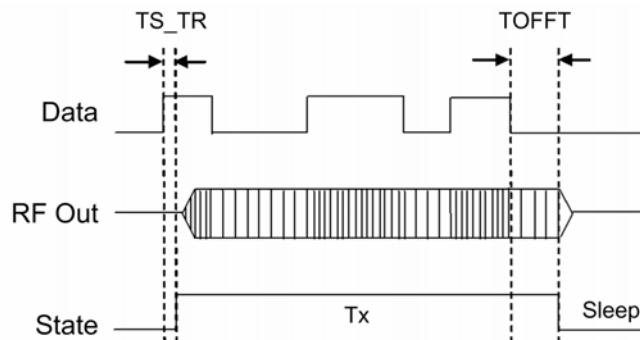

Figure 2. ‘Power & Go’ Mode: Transmitter Timing Operation

The transition back to Sleep mode is managed automatically. The RFM68W waits for TOFFT (2 or 20 ms) of inactivity on DATA before returning to Sleep mode.

In **Forced Transmit Mode** the circuit can be forced to wake up and go to TX mode by sending an APPLICATION instruction through the TWI interface, and setting the Mode bit DA(15) to ‘1’. Once in Transmit the circuit will transmit over the air the data stream presented on the DATA pin. The circuit will stay in transmit mode until a new APPLICATION instruction is sent with DA(15) to ‘0’.

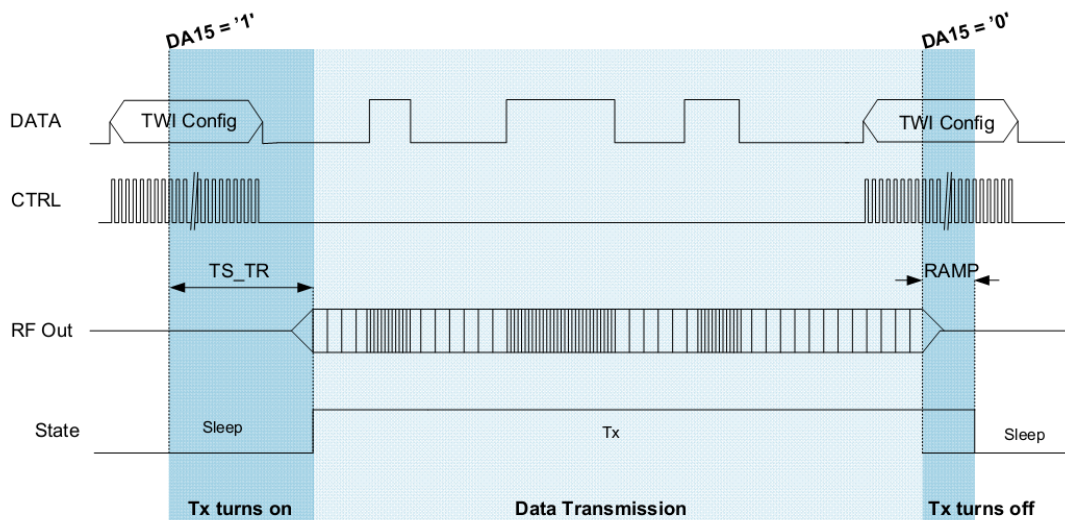

Figure 3. Forced Transmit Mode Description



4.2. Mode Selection Flowchart

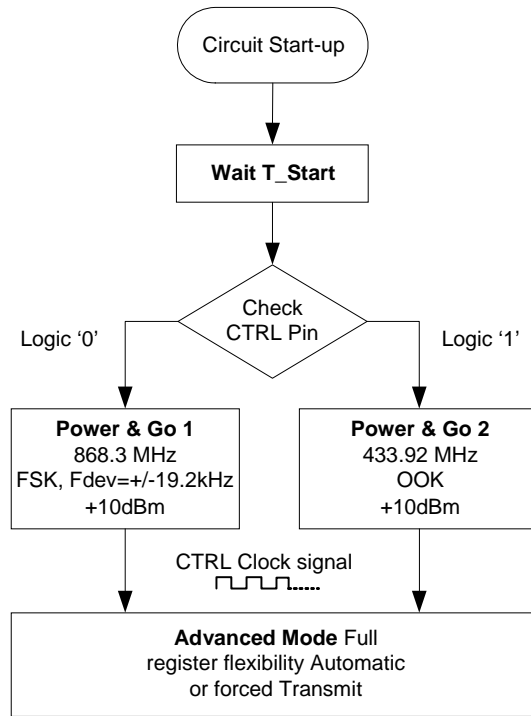

Figure 4. RFM68W Mode Selection

Note Advanced mode is entered only if DATA is held low during CTRL's rising edge.

When powering up the circuit (microcontroller and RFM68W), the logic level of the CTRL pin is sampled after T\_START, as described on Figure 5. During T\_START, the microcontroller IO driving the CTRL pin must be configured as an output, driving the CTRL pin to the desired state.

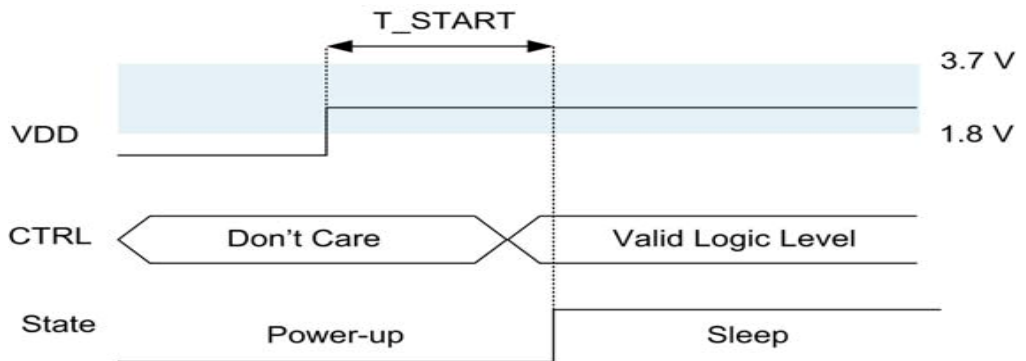

Figure 5. Power-up Timing

### 4.3. Application Mode: Power &Go

The default 'Power & Go' application mode sees the RFM68W configured as detailed in Table 6. By changing the logical state of the CTRL pin at Power-up or Reset, two distinct configuration modes can be selected. The Power & Go application modes hence permit microcontroller-less operation.

Table 6 Configuration in Power & Go Mode

CTRL Pin	Configuration	Mode
'Low'	FSK 868.3 MHz, +10 dBm, Fdev= $\pm$ 19.2 kHz	Power&Go 1
'High'	OOK 433.92 MHz, +10 dBm	Power&Go 2

### 4.4. Application Mode: Advanced

#### 4.4.1. Advanced Mode: Configuration

As described on Figure 4, Advanced mode is entered when accessing the Two Wire Interface (TWI) bus of the RFM68W. Upon communication to the register at up to 10 MHz of clocking speed, complete flexibility on the use of the chip is obtained.

Once all register settings are selected (see registers detailed description in section [5]), the RF68 can be used either in Automatic mode by simply toggling the DATA pin, or in Forced Transmit mode to optimize timings for instance.

#### 4.4.2. Frequency Hopping Spread Spectrum

**Frequency hopping** is supported in Advanced mode. After sending the data stream in the first channel, the user can send a Frequency change instruction containing the new channel frequency. The circuit will automatically ramp down the PA, lock the PLL to the new frequency, and turn the Power Amplifier back on. The user can then send his packet data on the new channel. Timings are detailed hereafter:

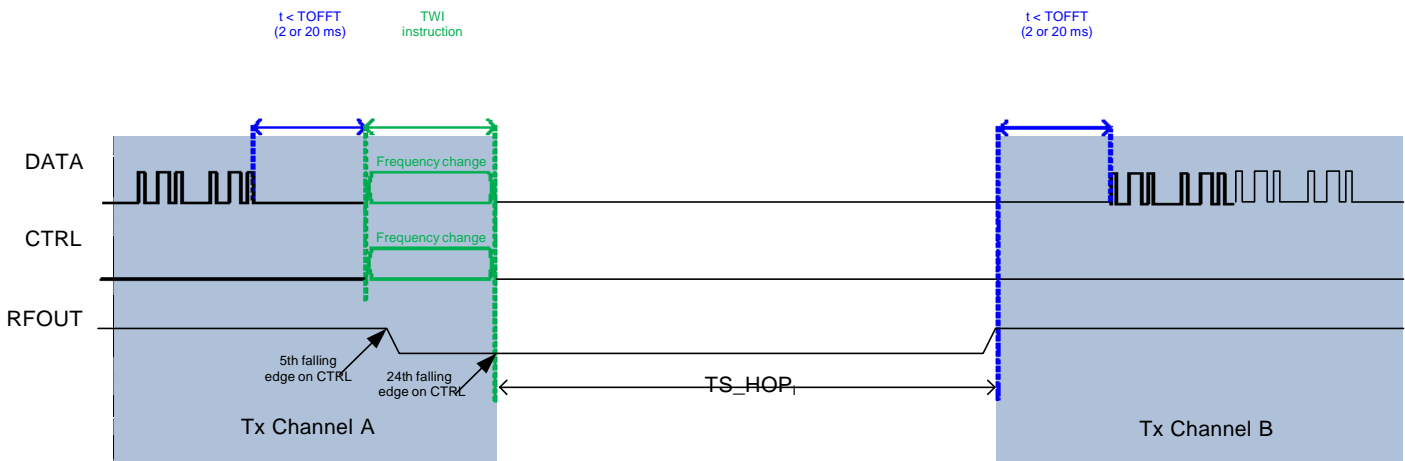

Figure 6. Frequency Hopping Description

- Notes
- During any TWI access, the input of the modulator is inhibited
  - The time between two Frequency change instructions shall be greater than  $TS\_HOP_i$
  - FHSS modulation, as described under FCC part 15.247, is supported by the RFM68W; also note that the large Frequency Deviation settings available on the RF68 make it suitable for "Digitally Modulated Systems", as described under FCC Part 15.247 (a)(2)

## 4.5. Frequency Band Coverage

The RFM68W offers several combinations of frequency references and frequency outputs, allowing for maximum flexibility and design of multi-band products:

Table 7 Frequency Selection Table

Reference Frequency FXOSC	Band Setting DA(13)	Upper / Lower Frequency Bounds	Fstep	Frff & Fdev
22 MHz	0	310 to 450 MHz	$Fstep = \frac{22 \times 10^6}{2^{14}} = 1.34277 kHz$	$Frff = DF(18;0) \times Fstep$ $Fdev = DA(12;5) \times Fstep$
24 MHz		312 to 450 MHz	$Fstep = \frac{24 \times 10^6}{2^{14}} = 1.46484 kHz$	
26 MHz		338 to 450 MHz	$Fstep = \frac{26 \times 10^6}{2^{14}} = 1.58691 kHz$	
	1	860 to 870 MHz and 902 to 928 MHz	$Fstep = \frac{26 \times 10^6}{2^{13}} = 3.17383 kHz$	

## 4.6. Power Consumption

The following typical power consumption figures are observed on the RFM68W kits. Note that the transmitter efficiency depends on the impedance matching quality, and can be PCB design dependant.

The PA matching may be different in each frequency band.

Table 8 Power Consumption in Tx mode

Frequency Band	Conditions	Typical Current Drain
310 to 450 MHz	Pout=+10dBm, OOK modulation with 50% duty cycle	11 mA
	Pout=+10dBm, FSK modulation	15 mA
	Pout=0dBm, FSK modulation	9 mA
860 to 870 MHz	Pout=+10dBm, FSK modulation	16.5 mA
	Pout=0dBm, FSK modulation	10 mA
902 to 928 MHz	Pout=+10dBm, FSK modulation	17.5 mA
	Pout=0dBm, FSK modulation	10.5 mA

## 5. RFM68W Configuration

The RFM68W has several configuration parameters which can be selected through the serial interface

### 5.1. TWI Access

As long as CTRL is kept stable, the DATA pin is considered by the circuit as the input for the data to be transmitted over the air (Power&Go modes).

Programming of the configuration register is triggered by a rising edge on the CTRL line. Upon detection of this rising edge, the data applied to the DATA pin is accepted as register configuration information, the data bits are clocked on subsequent rising edges of the clocking signal applied to the CTRL pin. The timing for RFM68W configuration register 'write' is shown in Figure 7. Note that, once triggered, all 24 clock cycle must be issued to the RFM68W.

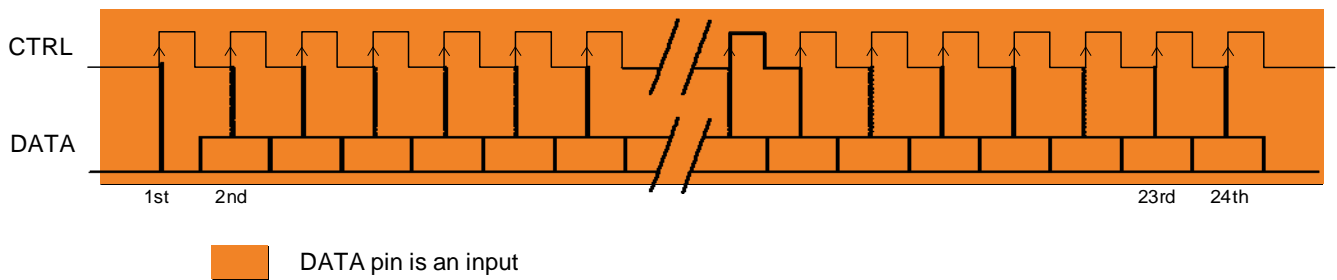

Figure 7. TWI Configuration Register 'Write'.

The registers may, similarly, be read using the timing of Figure 8.

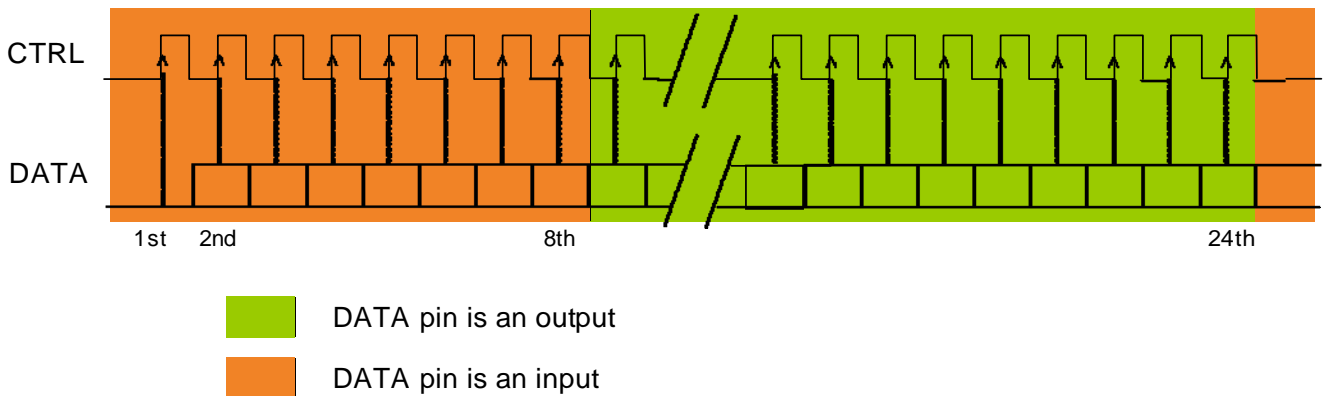

Figure 8. TWI Configuration Register 'Read'.

The first rising edge on CTRL which initiates the ADVANCED mode must occur at least 1 ms after the circuit has been powered up or reset.

Table 9 TWI Instruction Table

Byte 0				Byte 1				Byte 2				Instruction											
7	6	5	4	3	2	1	0	7	6	5	4		3	2	1	0	7	6	5	4	3	2	1
0	0	0	0	(0000)				DA(15:0)								Write Application bits							
0	0	0	1	1	DF(18:0)								Write Frequency bits										
0	0	1	0	(0)(0010)(0010)				DT(10:0)								Write Test bits (pad protected)							
0	0	1	1	(0011)				DA(15:0)								Read Application bits							
0	1	0	0	(0100)				DF(15:0)								Read the 16 least significant Frequency bits							
0	1	0	1	(0101)				DS(12:5)				DS(4:0)		DF(18:16)	Read Chip version, Status and 3 most significant Frequency bits								
0	1	1	0	(0110)				DS(28:13)								Read Bist signature							
0	1	1	1	(0111)				(1111)(1)		DT(10:0)						Read Test bits							
1	x											Discarded, not an instruction											
All 1												Recovery instruction											

- Notes
- The first "0" transmitted to the RFM68W is required to initialize communication
  - The following 3 bits (highlighted in blue) determine the type of instruction
  - The forthcoming bits (highlighted in green) define a protection pattern; any error in these bits voids the instruction

**5.2. APPLICATION Configuration Parameters**

Name	Number	Description	Power &Go 1	Power &Go 2
Mode	DA(15)	Mode: 0 → Automatic mode 1 → Forced transmit mode	0	
Modul	DA(14)	Modulation scheme: 0 → FSK 1 → OOK	0	1
Band	DA(13)	Band 0, 310 to 450 MHz Band 1, 860 to 870 MHz and 902 to 928 MHz	1	0
Fdev	DA(12:5)	RF Frequency deviation in FSK mode only See Table 7 for details	0x06 Fdev= +/-19.2kHz	Unused
Pout	DA(4)	Output power range: 0 → 0 dBm 1 → 10 dBm	1	1
TOFFT	DA(3)	Period of inactivity on DATA before RFM68W enters Sleep mode in Automatic mode: 0 → 2 ms	0	1
RES	DA(2:0)	Reserved	100	100

*Table 10 APPLICATION Configuration Parameters*

*Note* All changes to the APPLICATION parameters must be performed when the device is in Sleep mode, with the exception of DA(15). Mode can be sequentially written to “1”, and then “0” while the device is in Transmit mode, to speed up the turn off process and circumvent the TOFFT delay.

**5.3. FREQUENCY Configuration Parameters**

Name	Number	Description	Power &Go 1	Power &Go 2
Frf	DF(18:0)	RF operating frequency  See Table 7 for details	0x42CAD  Frf=868.3 MHz With 26 MHz reference	0x42C1C  Frf=433.92 MHz With 26 MHz reference

*Table 11 FREQUENCY Configuration Parameters*

If done in Sleep mode, the Frequency change instruction will be applied next time the RFM68W is turned on. If Frequency change occurs during transmission, the automated Frequency Hopping sequence described in section [4.4.2] will take place.

## 5.4. Test Parameters (internal)

Ten Test bits DT(9:0) exist in the RFM68W. They are only use for the industrial test of the device, and therefore they are pad protected. It means that their value cannot be modified without applying a specific logical level to some of the RFM68W pads during a write access.

## 5.5. Status Parameters

DS(12:5) are read-only bits, organized as follows:

Name	Number	Description	Default Advanced Mode	Power &Go 1	Power &Go 2
RES	DS(28:13)	Reserved		-	
Chip Version	DS(12:5)	Chip identification number		"0001 0001" --> V1A	
RES	DS(4:0)	Reserved		-	

*Table 12 Status Read-Only Parameters*

### 5.6. Recovery Command

In the event of spurious activity (less than 24 clock cycles received) on the CTRL pin, control over the TWI interface can be recovered in two possible ways:

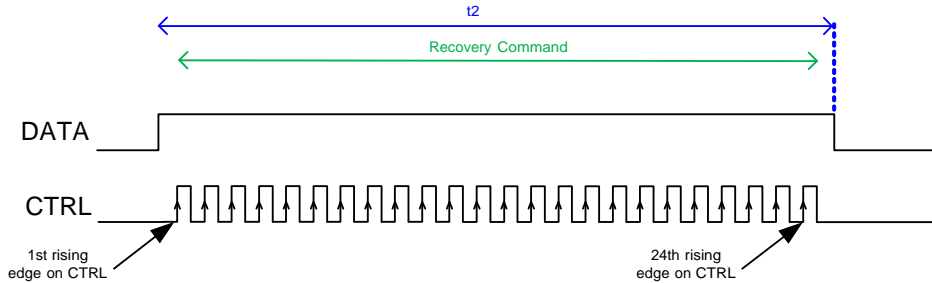

Figure 9. Quick Recovery Command

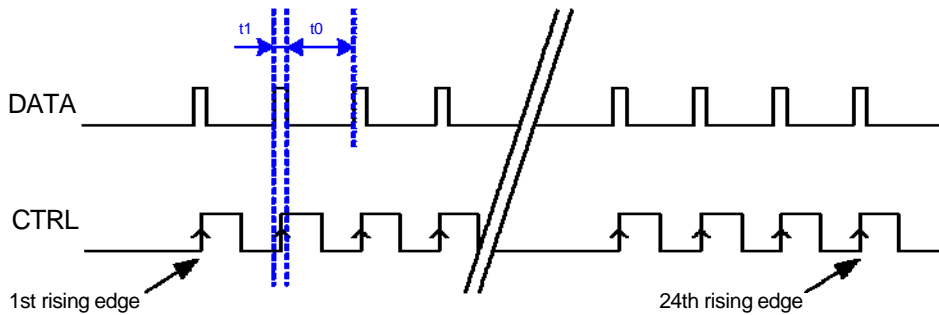

Figure 10. Pulsed Recovery Command

- Notes
- If  $t_2 < 5 \mu s$ , the RFM68W will not turn into Tx mode during the recovery command (if not previously in Tx mode)
  - If  $t_1 < 5 \mu s$ , with  $t_0 > 5 \mu s$ , the RFM68W will not turn into Tx mode in the second scenario of recovery command
  - During the Pulsed recovery command,  $t_0$  timing does not have any upper limit
  - If  $t_1$  or  $t_2$  exceeds  $5 \mu s$ , the recovery command will still be successful, but the transmitter will momentarily turn on



6. Application Information

Typical Application Schematic

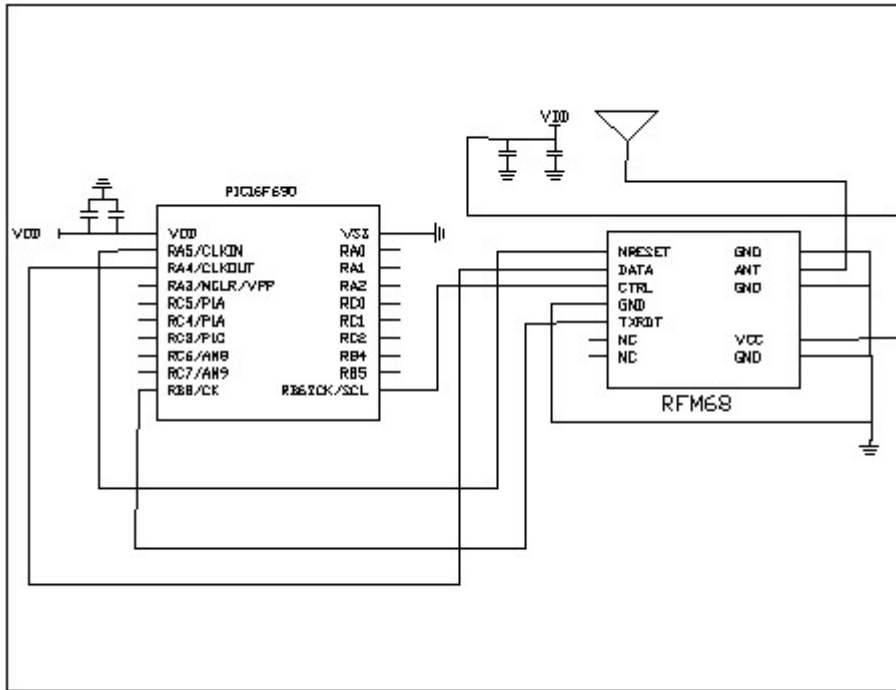

## 6.1. NRESET Pin

When required, the pin NRESET can be controlled externally, to allow for:

- ◆ either a delayed Power On Reset (POR) cycle of the RFM68W, allowing for the companion micro to reset and assign its port directions. This is achieved by connecting a R/C time constant to the NRESET pin.
- ◆ or an On-the-go Reset of the RFM68W at any moment in time, if required by the application. This is achieved by pulling the NRESET pin low for more than 100 microseconds, then releasing it to high impedance (normal termination).

## 6.2. TX\_READY Pin

For timing critical applications, TX\_READY pin can be useful to know precisely when the transmitter is ready for operation, and therefore save energy. To this end, TX\_READY can optionally be connected to inform the companion device that the PA ramp up phase has been terminated, hence the RFM68W is ready for data transmission.

## 6.3. Low Power Optimization

The RFM68W is designed to reduce the cost of the RF transmitter functionality. To this end, a single DATA signal can be enough to operate the transmitter, in any of the two Power & Go modes. In this situation, TS\_START and TOFFT timings, tabulated in Section 2.4, must be respected, leading to significant periods of time during which the transmitter is On and no valuable information is transmitted.

For more demanding applications where energy usage is critical, the RFM68W offers hardware and software support to accurately control the transmitter On time, and therefore save energy:

### 6.4.1. 2 Connections: CTRL, DATA

If the two signals of the TWI interface can be controlled by the host microcontroller, Tx On time can be accurately controlled as follows:

- ◆ At the device turn on, instead of waiting for TS\_TR (2ms max, but very XTAL dependant), the status flag TX\_READY
- ◆ can be polled on the TWI interface. As soon as the TX\_READY flag is set, the microcontroller can start toggling DATA to transmit the useful packet. This method is valid in both Forced Tx and Automatic modes.
- ◆ At the device turn off, instead of waiting for TOFFT (2 or 20ms), the user can immediately turn off the transmitter after
- ◆ the transmission of packet, assuming that the Forced Transmit mode was selected.

### 6.5.2. 3 Connections: CTRL, DATA, TX\_READY

In applications where the number of connections between the microcontroller and the RF chip is less critical, TX\_READY pin can be connected to either a GPIO port, or an external interrupt port of the micro. The two optimizations described in the former subsection will also be possible.

Package Information

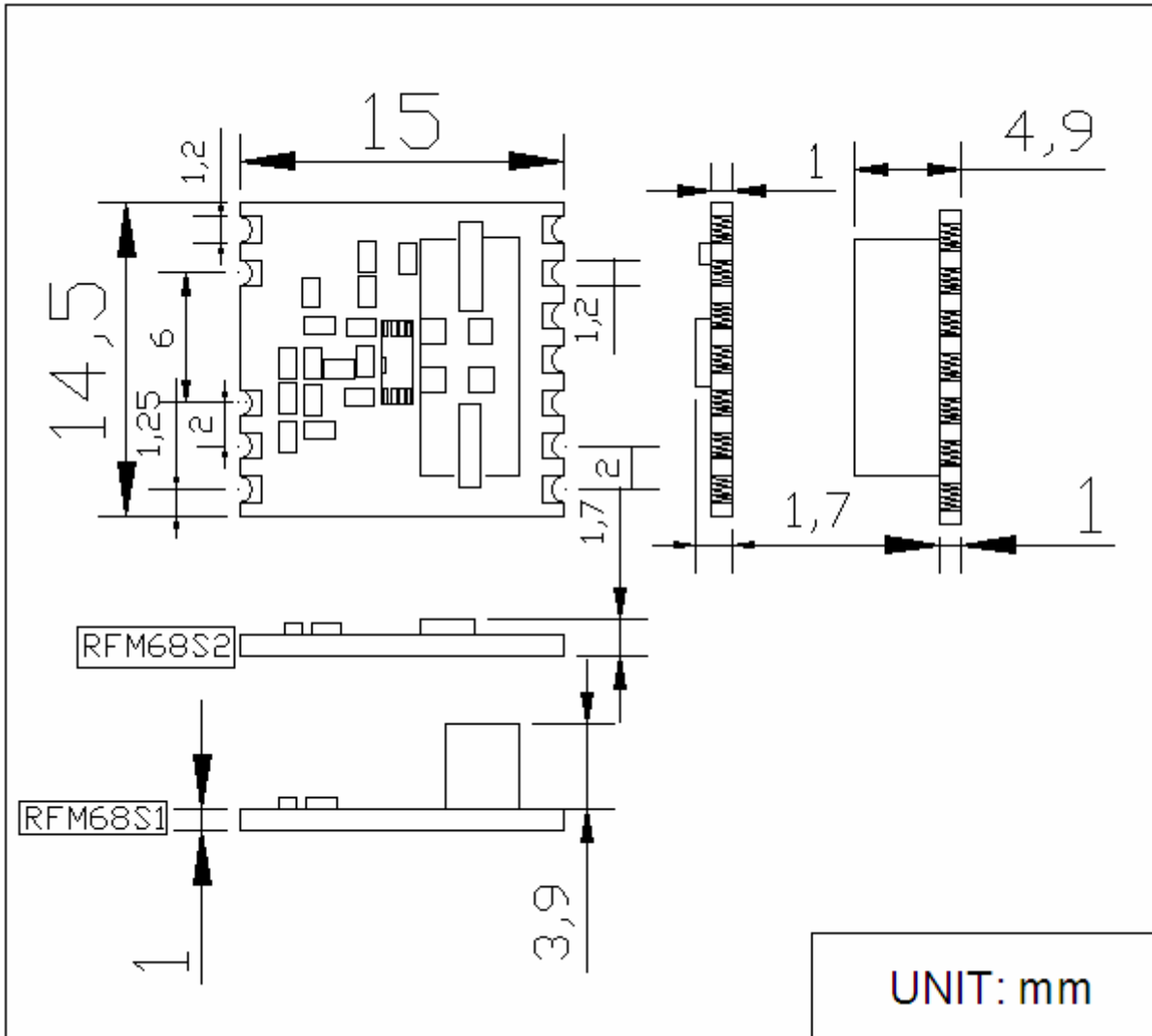

**HOPE MICROELECTRONICS CO.,LTD**

Add: 2/F, Building 3, Pingshan Private  
Enterprise Science and Technology  
Park, Lishan Road, XiLi Town,  
Nanshan District, Shenzhen,  
Guangdong, China

Tel: 86-755-82973805

Fax: 86-755-82973550

Email: [sales@hoperf.com](mailto:sales@hoperf.com)

Website: <http://www.hoperf.com>

<http://www.hoperf.cn>

This document may contain preliminary information and is subject to change by Hope Microelectronics without notice. Hope Microelectronics assumes no responsibility or liability for any use of the information contained herein. Nothing in this document shall operate as an express or implied license or indemnity under the intellectual property rights of Hope Microelectronics or third parties. The products described in this document are not intended for use in implantation or other direct life support applications where malfunction may result in the direct physical harm or injury to persons. NO WARRANTIES OF ANY KIND, INCLUDING, BUT NOT LIMITED TO, THE IMPLIED WARRANTIES OF MERCHANTABILITY OR FITNESS FOR A PARTICULAR PURPOSE, ARE OFFERED IN THIS DOCUMENT.

©2006, HOPE MICROELECTRONICS CO.,LTD. All rights reserved.